

Continuous LED lighting system for commercial applications

The Zipline combines architectural impact, longevity and supreme efficiency (192.1 LL/CW) providing the lighting designer with the perfect lighting solution for many building-wide applications.

Extruded aluminium trunking is connected to a range of luminaire modules. These modules can be a combination of luminaire, emergency luminaire, spotlight and passive infra-red detector and are designed to snap into sockets located at regular intervals, ensuring a fast, flexible installation.

With five power options, broad, narrow and double asymmetric light distributions and a variety of accessories the Zipline is a truly versatile lighting system.

Applications: retail, warehousing, manufacturing, schools, art galleries, data centres.

- Narrow, broad or double asymmetric distribution luminaire module options
- White extruded aluminium trunking
- Pre-installed wiring loom, module sockets at 750 mm intervals
- Plug and socket connections between trunking joints
- Modules click fit using stainless steel spring (requires a standard screwdriver to release)
- SmartScan wireless technology removes the need for control cabling. Ideal for retro-fit

Notes: See installation guide for mounting point locations



IP20

Up to 192.1 LL/CW

SMARTSCAN

LUXGUARD

Specification

Mounting	Surface Suspended	IP rating	IP20
Nominal size	1500 mm module	Max presence detection height	8 m

Lighting

Lumen output	4,400 lm - 11,060 lm	Efficacy	Up to 192.1 LL/CW
--------------	----------------------	----------	-------------------

Emergency data

Emergency lumen output	675 lm - 700 lm	Emergency type	Maintained
Emergency duration	3 hours	Battery specification	Nickel Metal Hydride (NiMH)

Power

LED power	22 W - 64 W	Circuit power	24 W - 67 W
-----------	-------------	---------------	-------------

LED characteristics

CRI	80+	Colour temperature	4000 K
Rated life (hours)	100 K - L70/B10		

Compliance

UKCA	Yes	CE	Yes
Energy efficiency class	This product contains a light source of energy efficiency class B		

Dimensions

White extruded aluminium trunking

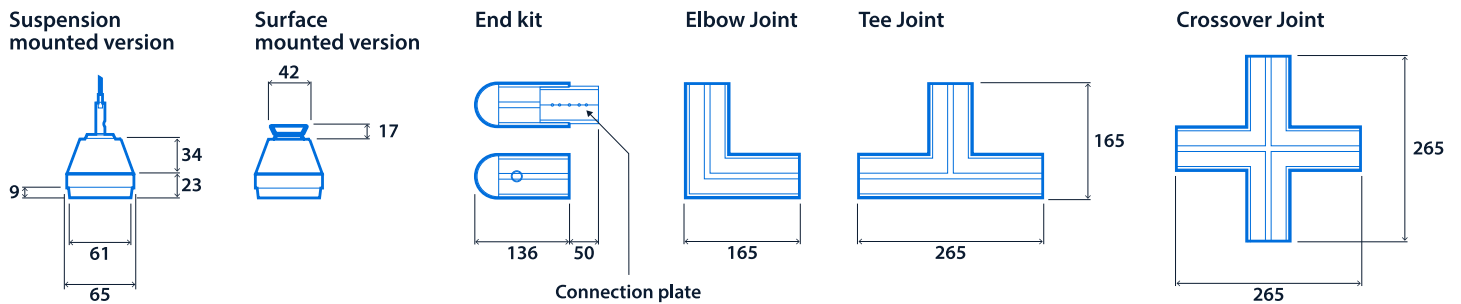

Raw galvanised steel trunking

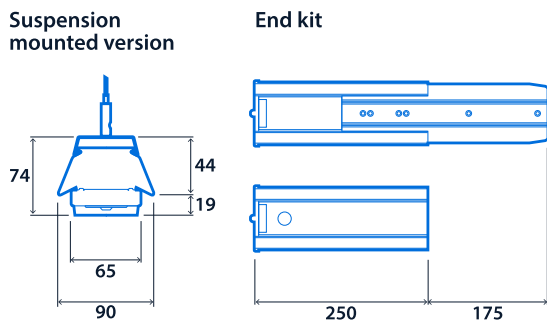

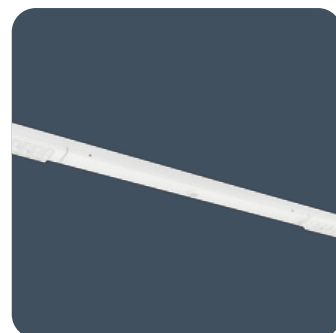
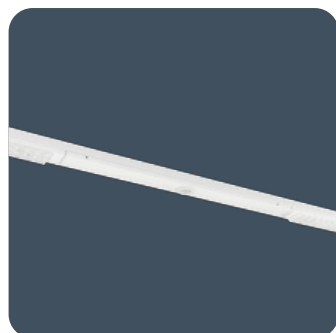

Firefly module

SmartScan module

PIR module

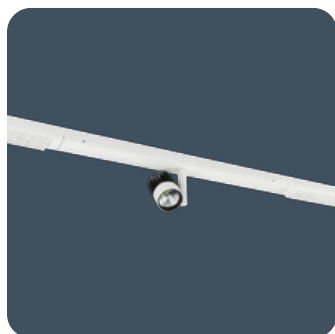

Single spotlight module

Twin spotlight module



Click or scan here
View Zipline variants using
our online filtering tool

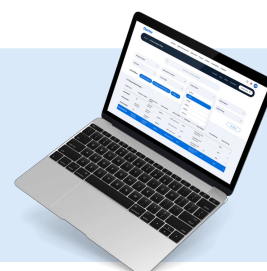

Information is correct as of 30 Jan 2025, however must not be interpreted as a guarantee of individual product performance and/or characteristics. We reserve the right to alter specifications and designs without prior notice.