

Corrosion resistant heavy duty bulkhead luminaires

Robust bulkhead luminaires for internal or external applications. Strong high-pressure die-cast aluminium body and frame with polycarbonate or thermally shock resistant borosilicate glass cover. Optional wire guard available.

Applications: walkways, loading bays, entrances, precincts and security areas. Ideal for industrial areas and power stations, cable tunnels, pump rooms and coal handling plants.

- Fixings outside gasket line to preserve IP rating
- Clip-on nylon coated steel wire guard available
- Tamper-resistant cover screws available
- Complies with M.O.D. JSP482 Chapter 8 Document for 'Category C' areas



IP66

Up to 115 LL/CW

LED PROTECT

Specification

Mounting	Surface	IP rating	IP66
----------	---------	-----------	------

Lighting

Optic	Prismatic cover	Lumen output	2,455 lm - 4,255 lm
Efficacy	Up to 115 LL/CW		

Power

LED power	20 W - 32 W	Circuit power	23 W - 37 W
-----------	-------------	---------------	-------------

LED characteristics

CRI	70+	Colour temperature	4000 K
Rated life (hours)	100 K - L90/B10		

Compliance

UKCA	Yes	CE	Yes
Energy efficiency class	This product contains a light source of MOD compliance energy efficiency class C		JSP482 Chapter 8 Document for 'Category C' areas

Dimensions

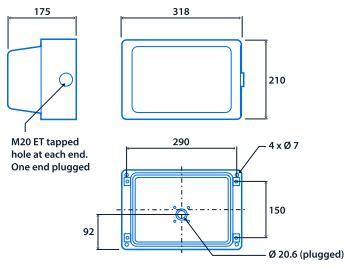

View the range



Information is correct as of 05 Jan 2025, however must not be interpreted as a guarantee of individual product performance and/or characteristics. We reserve the right to alter specifications and designs without prior notice.