

Adjustable recessed accent gimbals

Recessed single or twin head LED adjustable gimbal luminaires. Cast aluminium head providing 20 W, 28 W or 35 W – 17°, 28° or 41° beam versions. Each head uses CRI 90 new generation chip on board LED.

Applications: reception areas, retail, car showrooms.

- 17°, 28° and 41° beam angle versions
- Adjustable spots with tilt in all directions
- Supplied with remote gear unit fitted with 2 m lead
- Can be supplied pre-wired with a purpose made 1 m connection lead for plugging directly into the Smart Hub
- Fitted with CRI 90 LEDs with enhanced R9 value. Suitable for retail applications

Notes: Black and silver finishes or CRI 80 versions available to special order (minimum order quantity applies)

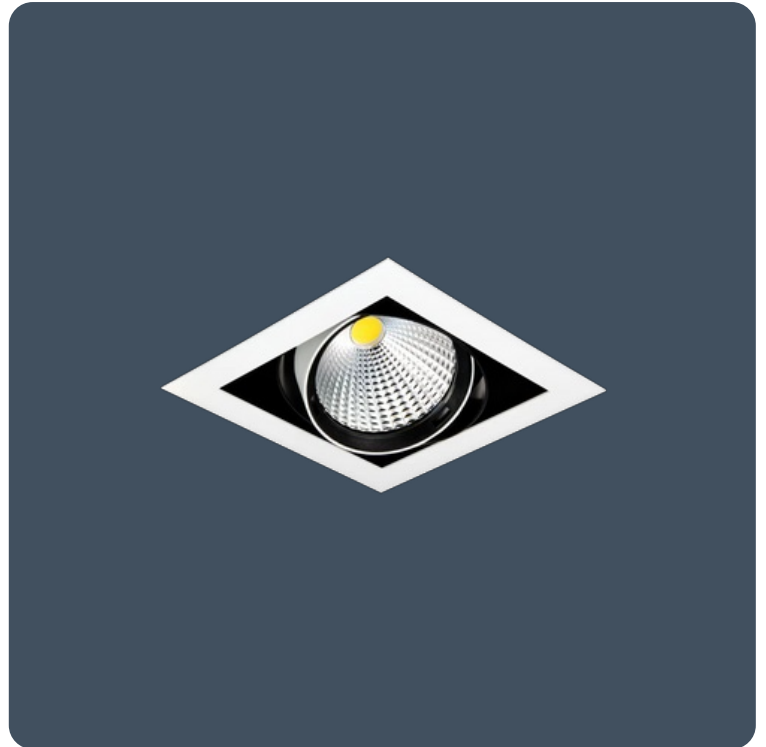

IP20

Specification

Mounting	Recessed	IP rating	IP20
----------	----------	-----------	------

Lighting

Lumen output	1,960 lm - 7,250 lm
--------------	---------------------

Power

LED power (multiple)	Up to 35 W	Circuit power (multiple)	Up to 41 W
----------------------	------------	--------------------------	------------

LED characteristics

CRI	90+	Colour temperature	3000 K 4000 K
Rated life (hours)	50 K - L70/B10		

Compliance

UKCA	Yes	CE	Yes
------	-----	----	-----

Dimensions

Single Version

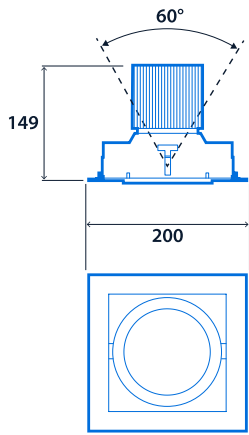

Cut-out - 182 x 182
Minimum ceiling void - 200

Twin Version

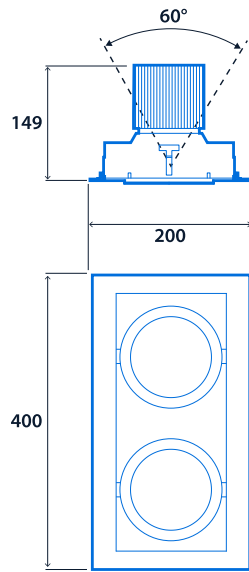

Cut-out - 380 x 182
Minimum ceiling void - 200

Downlighter Power Unit

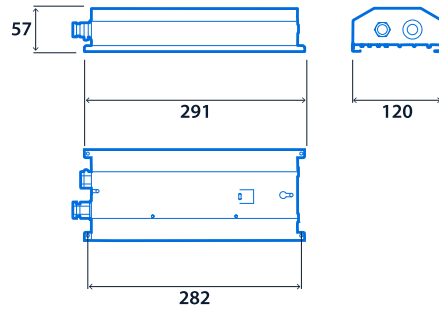

Standard Remote Driver

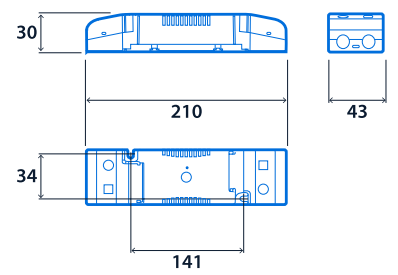

Click or scan here
View Solis-L variants using
our online filtering tool



Information is correct as of 28 Jan 2025, however must not be interpreted as a guarantee of individual product performance and/or characteristics. We reserve the right to alter specifications and designs without prior notice.